

# INOX | Upright Cabinets

REFRIGERATED CABINETS ▶ GN2/1-NO FROST ▶ FREEZER

QN 14



## DETAILS

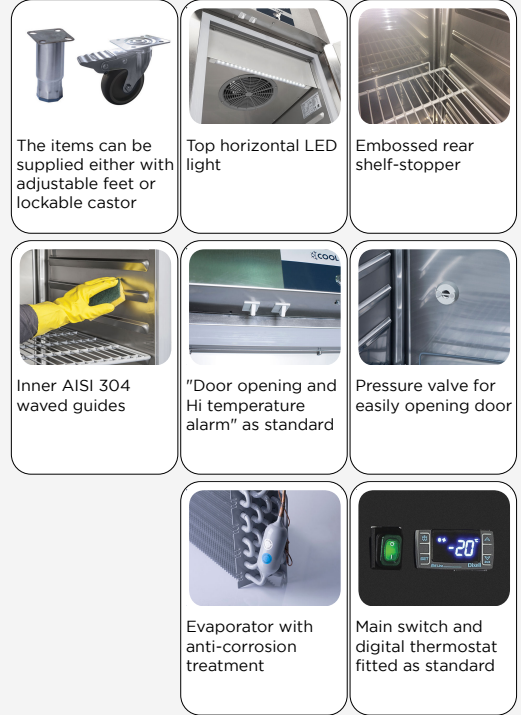

## GENERAL FEATURES

- GN2/1 Freezer upright cabinet (CLASS C)
- Stainless Steel exterior and interior
- Plastic thermal-braker as chamber body frame (Hot pipe system)
- Inner with embossed rear shelf stopper and wave for easy cleaning
- Ventilated Cooling
- Evaporator with anti-corrosion treatment
- Automatic defrost with electric heater
- Foaming Agent Cyclopentane (85mm)
- Digital thermostat with "opening door" and "Hi temperature" alarm
- Removable Gasket
- LED light and lock fitted as standard
- Door with self closing door
- Adjustable shelves GN2/1: 6 + 2 + 3 middle
- N.4 S/S Adjustable feet - (Lockable castor as Optional)
- Energy efficiency class: C

## TECHNICAL SPECIFICATIONS

External Dimensions (WxDxH mm)	1430x918x2085
Internal Dimensions (WxDxH mm)	1260x665x1390
Noise level	62 dB(A)
Consumption	8.23 kWh/24h
Capacity	1105 L
Rated Power	370 W
Net Weight	257 Kg
Temperature	-18°C ~ -22°C
Gross Weight	288 Kg
Packaging dimensions (WxDxH mm)	1450x930x2170
Loading quantities 20'/40'/40'HQ	7/16/16

## PRODUCT DIMENSIONS

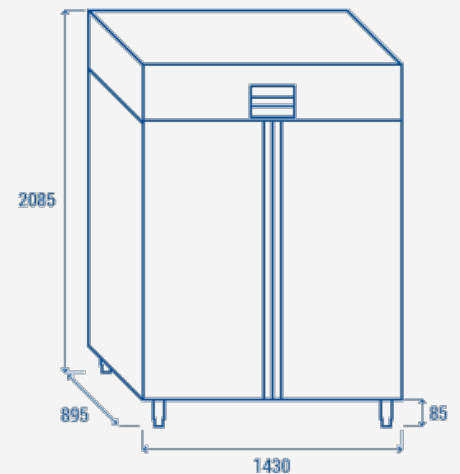

## CERTIFICATION

CE RoHS

